



# FIDDLE

## THE 2-NOTE MINOR CHORD SHAPES (the notes in the blue squares are slide notes)

### STEP shape

This chord is a Flat 5<sup>th</sup> chord in root position - made up of the root and the flattened 5<sup>th</sup> note of the scale. There is no 3<sup>rd</sup>.

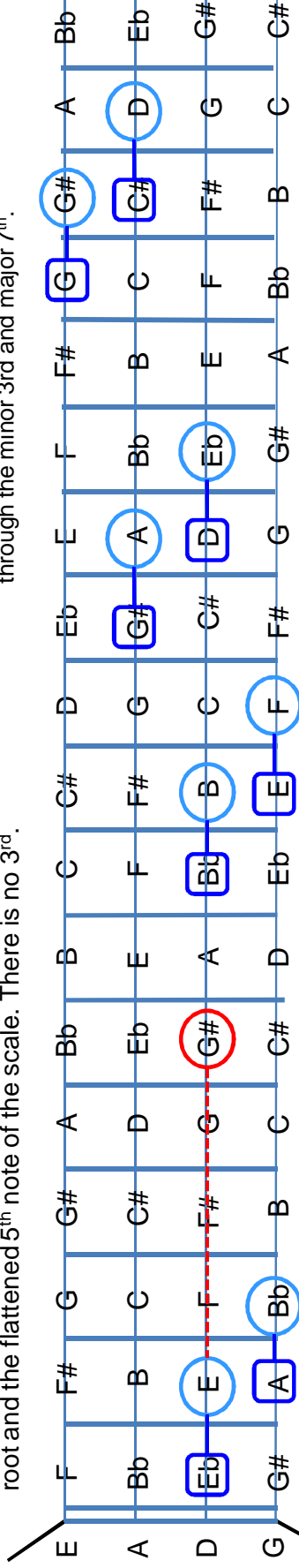

When you slide into the **Step** shape you pass through the minor 3<sup>rd</sup> and major 7<sup>th</sup>.

This chord shape can be on any 2 consecutive strings, anywhere up the fingerboard using the 1<sup>st</sup> and 2<sup>nd</sup> fingers. This shape only sounds bluesy with the slide so does not work using an open string.

The notes in the **red circle** is the flat 7<sup>th</sup>s Try adding this with your 4<sup>th</sup> finger as a single notes, rather than as part of the chord. It works for all the above patterns

### STRADDLE shape

This chord is a Minor 3<sup>rd</sup> chord in root position - made up of the root and the minor 3<sup>rd</sup> note of the scale. There is no 5<sup>th</sup>.

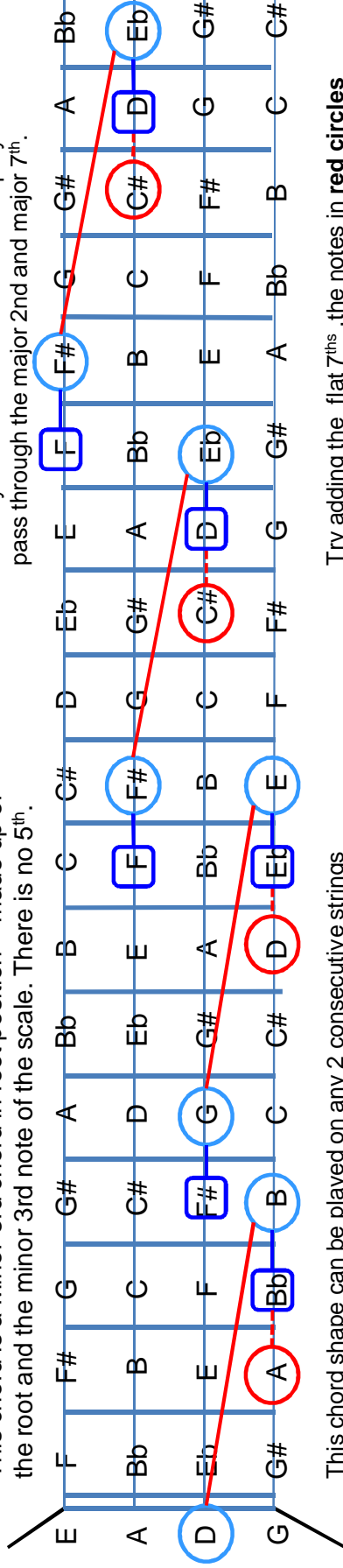

This chord shape can be played on any 2 consecutive strings anywhere up the fingerboard using the 3<sup>rd</sup> and 1<sup>st</sup> fingers. This shape can still sound bluesy using 1 open string and sliding just with the 2<sup>nd</sup> finger on the other string.

Try adding the flat 7<sup>th</sup>s, the notes in **red circles** with your second finger. Play them as individual notes or part of a long slide.